



MovieTech

**MANUAL
MAGNUM
DOLLY
SYSTEM**



Movie Tech AG
Martin-Kollar-Str. 9
81829 München
Germany
Tel. +49 (0)89 43 68 91 3
Fax. +49 (0)89 43 68 91 55
info@movietech.de

Movie Tech Sagl
Via Corti 5
6282 Balerna
Switzerland
Tel. +41(0) 91-6830606

k.shore@movietech.de

WWW.MOVIETECH.DE

Contents:

Part I: The MAGNUM Dolly System

General Safety Tips	Page 4
Technical Specifications	Page 5
The MAGNUM Basic-Dolly	Page 6
MAGNUM Dolly Wheel Arm Settings	Page 8
Base Plate with Euro Adapter Mount	Page 10
MAGNUM Electromechanical Column	Page 11
DUO Jib Arm	Page 14

Part II: The control of the MAGNUM Dolly

Mode 0 - storage of upper and lower position	Page 19
Mode 1 - storage of max. 30 positions	Page 22
Mode 2 - storage complete drive up to 4 Min. 20 Sec.	Page 26
Mode 3 – operation via serial interface	Page 29
Error messages scheme and error correction power supply 48 Volt	Page 30
Arrangement of controls on the electronic front	Page 33
Explanation multifunctional display	Page 34

Control Unit	Page 35
SMD – LED advice on the board and function	Page 38
Layout fuse	Page 39
Handling and care of MAGNUM batteries	Page 40
Error messages power supply 110 or 220 Volt	Page 41
Instruction manual charger Magnum Dolly 24/48V since 2004	Page 42
EC-Declaration of Conformity	Page 43

Part I – The MAGNUM Dolly



General safety tips:

- 1) The MAGNUM Dolly should only be used on a stable, flat and horizontal underground.
- 2) At all times, the entire lift range of the MAGNUM column, jib-arms incl. Duo Jib (max. platform height 272 cm / 8.9 ft) etc. must be kept clear and free from obstructions (0.5 m / 19.7 in clearance in all directions), whether switched on or off, at all times. When operating beware of pinch points.
Attention: The Duo Jib Arm may not be mounted or operated when the MAGNUM Dolly is fitted with pneumatic wheels.
- 3) Attention in automobiles or uneven surfaces. The MAGNUM Dolly must be secured so that it cannot move or roll.
- 4) In the electromechanical column there are 3 pneumatic springs which are under constant high pressure. Should the column be damaged or the mechanics interfered with, it may eject with high speed and strength. The drive belt must be inspected and if necessary replaced after every 100 operational hours or at least every 12 months. The load carrying device must be inspected after every 100 operational hours. To inspect or repair the column, the column must be extended fully to relax the pneumatic springs.
- 5) Absolute attention to balance must be observed at all times especially during set-up and operation. Caution: Tipping danger!
- 6) When operating the Duo Jib in open air, the maximum operational wind speed of 32 km/h (19 mph) may not be exceeded. This applies even in halls, where the gates are open more than 1/3 of the upstream wind of the hall walls. Analog DIN 1055, Part 4, Section 6.3.1.
- 7) When operating from mains, all usual guidelines for operating electrical equipment must be observed.
- 8) All electronical components should be protected from over exposure to moisture and humidity.
- 9) It is recommended to use safety belts when operating at a fall height above 1,50 m (5 ft).
- 10) To prevent a uncontrolled dropping of the MAGNUM column while using a Duo-Jib, a catch screw nut, which does not carry in normal operation, is built-in (series built after May 2009 on). It takes over the carrying function as a safety element at a possible failure of the piston stroke mother. However, it is not appropriate for driving the column. An occurred intervention of the catch screw nut can be closed from the following:
 - Changed driving noise of the piston stroke column (loud, metallic)
 - Increased and further disconnection of the control with the error messages **"Err.9"**

In this case, the operation of the MAGNUM Dolly with Duo Jib immediately has to be terminated and the defect must be repaired! To do so, please contact the manufacturer.

Technical Specifications

Basic Dolly

Weight:	62 kg / 136 lbs
Minimum size for transport:	
Length:	64 cm / 25"
Width:	64 cm / 25"
Height:	37 cm / 14,5"
Max. Payload Capacity:	1000 kg / 2200 lbs
Maximum track width:	62 cm / 24"
Minimum track width:	36 cm / 14"

Basic Dolly and Electromechanical Column

Weight of MAGNUM Column:	78 kg / 171 lbs
Transport size, assembled:	
Length:	64 cm / 25"
Width:	64 cm / 25"
Height:	80 cm / 31"
Maximum Payload Capacity:	148 cm / 58"
Column extended:	250 kg / 550 lbs
Column retracted:	800 kg / 1763 lbs
Max. height (euro-adapter):	148 cm / 58"
Min. height (euro-adapter):	80 cm / 31"
Lift range:	68 cm / 28"
Fastest time through column lift range:	
24 V	4,5 sec
48 V	3,2 sec

Battery performance when fully ranged:	150 column moves
Battery capacity:	8 Ah
Battery charge current:	24 VDC
Charge cycle with mains	approx. 8 hrs
Mains voltage:	110 / 220 V AC
Mains input voltage (2 versions available)	110 or 220 V AC

MAGNUM Dolly with Duo-Jib

Maximum Payload Capacity including 2 pers.	
with High Rig mode (photo 3c)	200 kg / 440 lbs
with Low Rig mode (photo 3)	220 kg / 484 lbs
Standart mode (photo 3a & 3b)	250 kg / 550 lbs
Max. Platform Height:	272 cm / 107"
Min. Platform Height:	26 cm / 10"
Lift range:	150 cm / 59"

MAGNUM Dolly with Duo-Jib and TV-Platform

Maximum Payload Capacity including 1 pers:	192 kg / 423 lbs
Maximum Platform Height:	209 cm / 82"
Minimum Platform Height:	59 cm / 23"
Lift range:	150 cm / 59"

MAGNUM Dolly with Mini-Jibarm

Maximum Payload Capacity:	80 kg / 176 lbs
Maximum Height (euro-adapter):	235 cm / 93"
Minimum Height (euro-adapter):	70 cm / 27"
Minimum Height with Mini Low Rig:	9 cm / 3"
Lift range:	165 cm / 65"

MAGNUM Dolly Low Rig

Maximum Payload Capacity:	130 kg / 286 lbs
Maximum Height (euro-adapter):	78 cm / 30"
Minimum Height (euro-adapter):	10 cm / 4"
Lift range:	68 cm / 26"

The MAGNUM Basic-Dolly

Picture: The MAGNUM Basic-Dolly

Components Basic Dolly

- | | | |
|------------------------|------------------------------|--------------------------|
| 1. steering rod | 6. tension adjuster | 11. wheel setting clamp |
| 2. steering rod socket | 7. locking screw wheel axles | 12. table bearing |
| 3. wheel arm lever | 8. studio wheel | 13. locking screw |
| 4. carry grip | 9. track wheel | 14. column locking screw |
| 5. tension adjuster | 10. wheel brake | 15. Euro adapter plate |

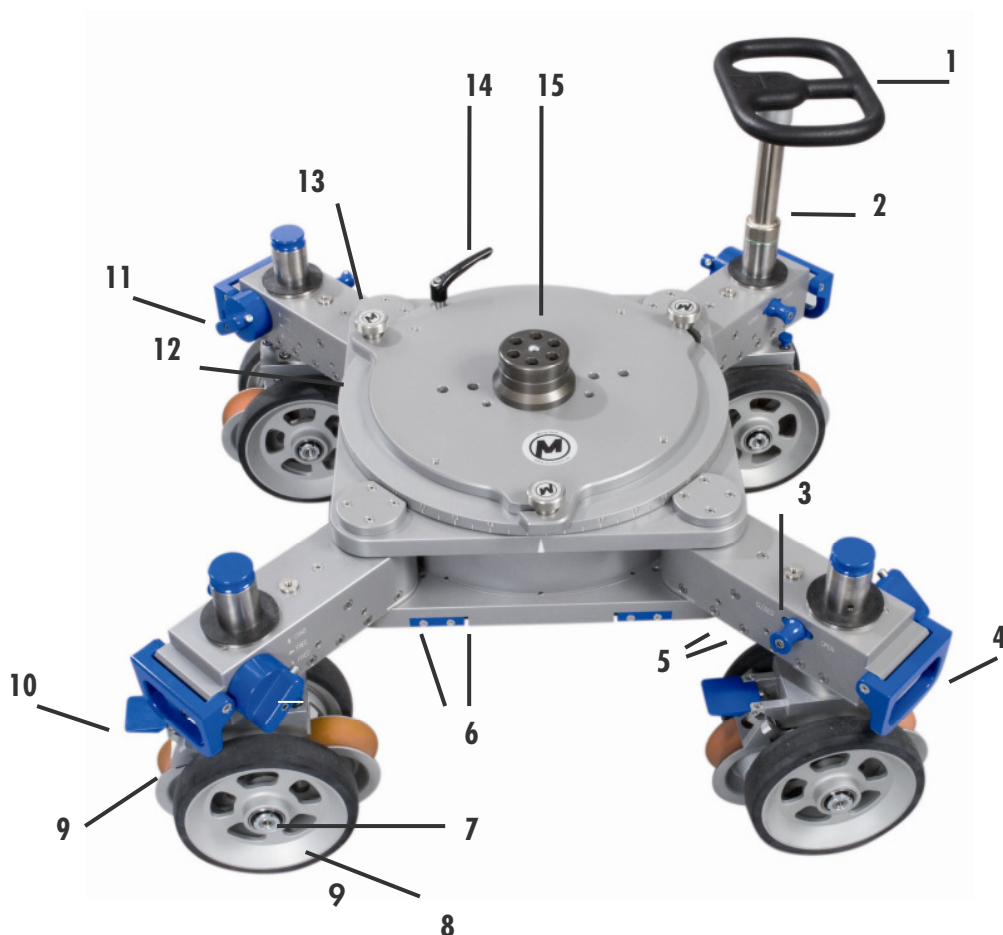

The Basic Dolly is the basis of the MAGNUM Dolly System. It allows manoeuvrability in a number of ways.

The wheel arms may be set in 16 different positions (see Figure 1).

Wheel Arm Positioning:

The wheel arms may be repositioned by pulling the Wheel Arm Lever (pos. 3, photo 1). After reaching the required position, the Wheel Arm Lever should be gently released allowing the locking pin to slip into place. Ensure that the wheel arm is fixed securely after every repositioning.

Combi-wheel Settings

The Basic Dolly has 4 combi-wheels. Each combi-wheel consists of 2 studio wheels and 1 or 2 track wheels. The studio wheels can be exchanged for pneumatic wheels. This is done by simply removing the locking screw (pos. 7) and removing the studio wheel. The pneumatic wheel is mounted in the same manner and locked in position with the locking screw.

Note: The integrated Track Wheels allow smooth tracking movements without having to change the Combi-wheels.

For operating on track the wheels should be set at the FREE position to enable them to compensate the tracks curve.

Ensure that the track is supported correctly and completely leveled!

The Wheel Setting Clamp (pos. 11) has 3 settings:

- CRAB** -> Enables connected steering of the wheels.
- FREE** -> Enables the wheels to rotate freely (for use on track).
- FIXED** -> Allows the wheels to be locked at set angles of 45 degrees.

Examples for possible wheel settings on the next page.

MAGNUM Dolly wheel settings

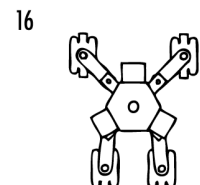
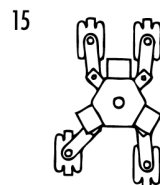
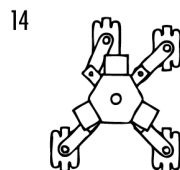
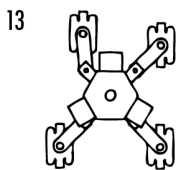
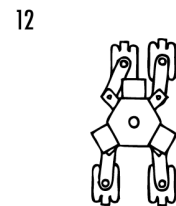
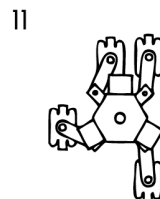
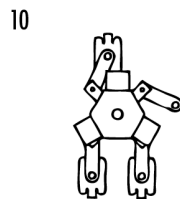
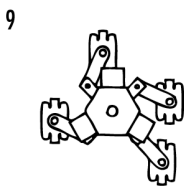
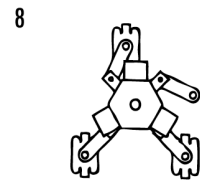
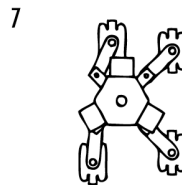
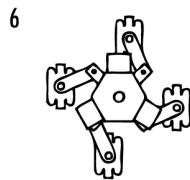
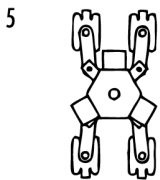
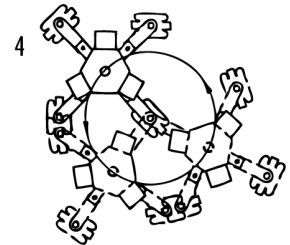
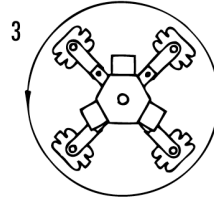
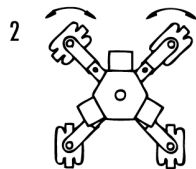
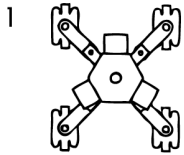

Rotation around an off-set axis (fig. 14)

1. Extend all wheel arms fully.
2. Choose one of the combi wheels as rotation center
3. With the Wheel Setting Clamp (pos.11) set this combi-wheel on FREE.
4. The combi-wheel on the opposite side (diagonally) should be set on FREE and then positioned at 90° to the wheel arm. By selecting FIXED, this combi-wheel position will be secured. This combi-wheel may be used as the steering point.
5. The remaining two combi-wheels should be set on FREE and positioned at 45° to each of their wheel arms. These wheel positions may be locked by selecting FIXED.

Rotation around own central axis (fig. 13)

1. Extend all wheel arms fully.
2. With the Wheel Setting Clamp (pos 11) put all wheels on FREE
3. Set all four combi-wheels at 90° to each of their wheel arms.
4. With the Wheel Locking Clamp, set all wheels on FIXED.

Two wheel steering (fig. 12)

1. With the Wheel Setting Clamp (pos.11) set all wheels on CRAB and set them in straight direction.
2. Select two of the combi-wheels that are parallel to each other and set them on FIXED.
3. Put the steering rod in the Steering Rod Socket (pos.2) of either of the two wheels that are set on crab.

To return to 4 wheel steering set the wheel setting clamp on each of the wheels at CRAB. Turn the steering rod until all 4 wheels connect. The Basic Dolly can be steered from each of the 4 wheel arms provided the designated wheel arm is switched to Crab.

Should the combi wheels of the Basic Dolly need adjustment because they are not running straight,(e.g. due to a bump or knock) the following action needs to be taken.

Older models:

Ensure that the locking clamps of all the combi-wheels are set at FIXED.

Open the Locking Bolt above the combi-wheel with an Allen Key.

With the help of a wheel locking bar, water level or any straight object align the wheels so that each set of two wheels are parallel to each other.

Re-lock the Locking Bolt.

Newer Models:

Ensure that the locking clamps of all the combi-wheels are set at lock.

Directly above the track wheel there are 2 locking bolts. Loosen the locking bolts with an Allen key.

With the help of a wheel locking bar, water level or any straight object align the wheels so that each set of two wheels are parallel to each other.

Re-lock the locking bolt.

The Basic Dolly contains a rotatable bearing (pos. 12) which allows to completely pan the columns etc mounted on it. The rotatable bearing may be locked with the Rotatable Bearing Brake (pos. 15).

Maximum payload on the Basic Dolly is 1000 kg.

The Basic Dolly accommodates 2 different fixtures:

1. Base Plate with Euro Adapter Mount
2. The MAGNUM Electromechanical Column

Base Plate with Euro Adapter Mount

The base Plate with Euro Adapter Mount (pos. 15), as with both possible fixtures, is mounted on the Basic Dolly by simply positioning it on the dolly so that the 3 bayonet connections may be locked into position by the 3 Locking Screws (pos. 13). Ensure that all 3 locking levers are tightened securely.

The Base Plate accommodates any accessory that connects to a Euro Adapter Mount.

MAGNUM Electromechanical Column

Picture: Manual Electromechanical Column

Components MAGNUM-Column

- | | | |
|---------------------------------------|------------------------------|-----------------------------------|
| 1. Hand control unit | 7. Hand control connector | 13. Turnstile mount |
| 2. Connection for carry bars | 8. Emergency switch | 14. Locking screw turnstile mount |
| 3. Duo Jib connection for support rod | 9. Digital display | 15. Turnstile |
| 4. Program channel | 10. Battery | 16. Brake for Turnstile |
| 5. Ramp mode switch | 11. Foot rest platform | |
| 6. Cable connection hand control unit | 12. Adjustable seat arm bolt | |

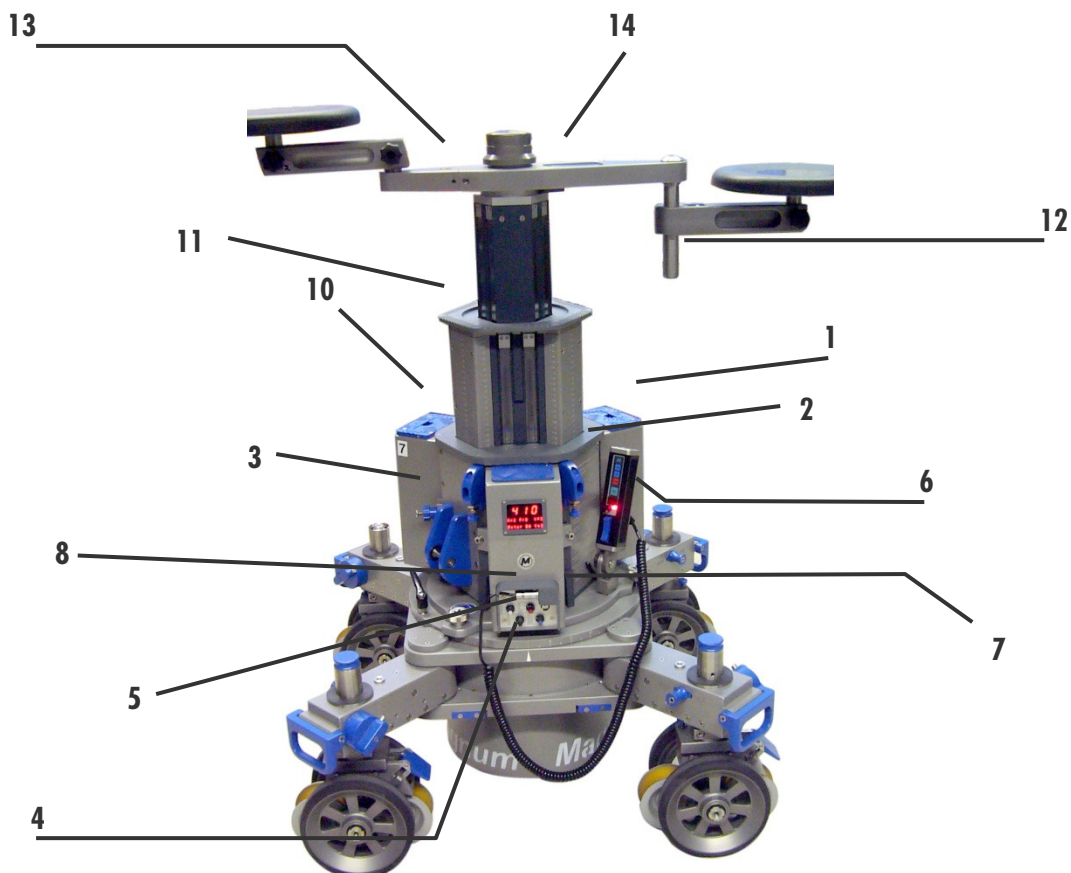

To operate the MAGNUM Column to its full potential it is important to understand the basic principles of how this column functions. We have endeavoured to explain this in simple terms.

The MAGNUM's motor, which is connected to a central spindle by means of a drive belt, powers the column upwards or downwards. Three pneumatic springs exerting an upward pressure of 2700 N and provide the extra strength necessary to carry a maximum payload of 250kg. It is important to remember that the motor uses the least amount of energy when the column is loaded with approx. 150kg. This point should be taken into consideration when operating with battery power. To achieve the longest consumption time with a battery, always load the column.

Therefore: Operate the column for a maximum battery operating time only in loaded condition!

Min. payload 80kg/ ideal payload 150kg / max. payload 250kg

The coordinating factor in the whole system is the MAGNUM Electronic. The electronic provides the motor with the instructions needed to allow smooth coordinated movements of the column. These instructions are in turn transmitted to the electronic from the operator via the Hand Control Unit.

When the MAGNUM Dolly is switched on, the initial stage is "stand by" i.e. the electronic system is activated. Within the first 1-2 seconds of activation the self diagnostic electronic makes an automatic system check to ensure that there are no faults present. In stand-by condition the column is held in position by an electromagnetic brake. By pressing the manual control switch the electromagnetic brake is deactivated and the motor moves the column up or down. When the column is no longer moving the motor holds the present position of the column automatically. After 8 seconds the brake closes again and holds the column in position. During this time the motor is moving or regulating the column's position, energy consumption is at its highest. After activation of the electromagnetic brake energy consumption drops dramatically to an absolute minimum.

Battery operated: Standard use with 2 x battery = 48V

In case of emergency 1x battery + short-circuit connector = 24V or

Power supply 115V oder 230V

One or two batteries can be connected to the column by means of the socket flanges (pos. 3, photo 10). The MAGNUM will work with one battery or two. When operating with two batteries, energy will be consumed from both batteries simultaneously. For longer operational time it is recommended to use two batteries. It is also recommended to keep two fully charged batteries in reserve. When the battery reaches 34 V, an automatic shut-down will take place. The digital display on the electronic will show Err Nr. 6. The unloaded battery should be replaced by 2 fully charged batteries. This automatic shut-down is meant to protect the batteries from being deeply unloaded i.e. below 17 V.

See page 50 for information on handling and care of the MAGNUM batteries.

Getting Started – 48 Volt Version

Once the power supply has been provided the following procedure should be followed.

1. Ensure that the General Safety Tips have been followed
2. Connect the Hand Control Unit (pos. 6) via the Hand Control Cable to the Control Cable Socket (pos. 8) in the Electronic Unit Housing.
3. Select the required drive ramp (pos. 6).
4. Activate the electronic by pressing the Main On / Off Switch integrated in the Hand Control Unit and wait until the self-test is finished (3 sec.)
5. Press the Manual Control Switch in the desired direction i.e. forwards to go up, press back to go down.

Note: After activation should the column be in a fully retracted or extended position, it is necessary to clear the two end switch areas. This simply means that the column should be driven, depending upon the activating position, either upwards or downwards approximately 110mm. The column is now fully operational.

6. **Attention:** Wait approx. 8 sec after the last up- or down movement before switching off the column completely,!

DUO Jib Arm

Picture: DUO-Jib-Arm

Components Duo-Jib-Arm

- | | | |
|---------------------------|---------------------------------|-----------------------|
| 1. Connection Pin | 8. Fixing Lock | 15. Platform Leveller |
| 2. Counterweight Rod | 9. Anchor Bracket Column | 16. Middle Section |
| 3. Counterweight Triangle | 10. Platform | 17. Connection Pin |
| 4. End Section | 11. Platform Locking Lever | 18. End section Lock |
| 5. Anchor Bracket Duo Jib | 12. High/ Low Rig Locking Lever | 19. Parallelogram Rod |
| 6. Automatic Locking Pin | 13. High/ Low | |
| 7. Connector Rod | 14. Front Section | |

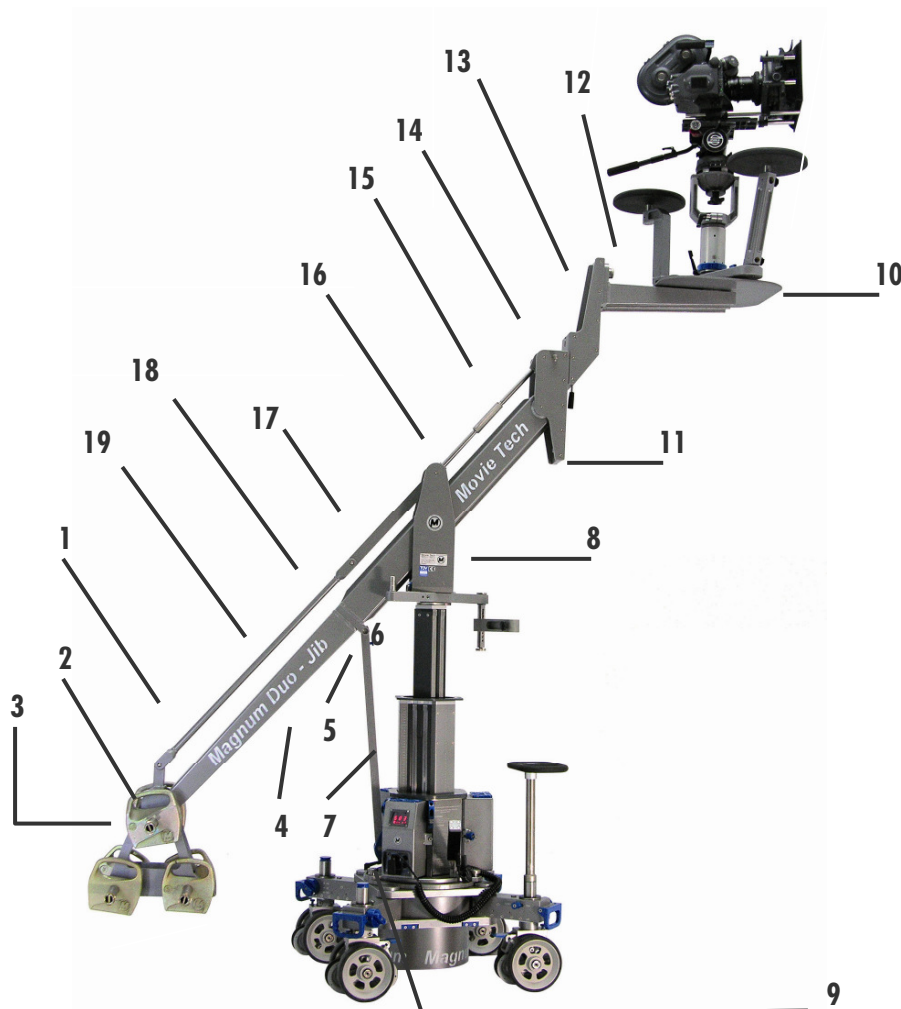

The Duo Jib Arm may only be used on the MAGNUM Dolly. The following set-up instructions should be observed.

Attention: Before set-up and at all times during operation, ensure that either Drive Ramp 3 or 4 is selected. Do not operate the Duo Jib on Drive Ramp 1 or 2.

In the event of a power failure due to an electrical or battery cut out, it is recommended to have an appropriate ladder to enable the camera crew to dismount.

Attention: Do not use pneumatic wheels when mounting or operating the Duo Jib!

Set up:

1. Extend all 4 wheel arms of the Basic Dolly fully (pos. 1, page 8).
2. Mount the middle section (pos. 16) of the Duo Jib onto the column by connecting it to the Euro Adapter Mount.
3. Connect the Connector Rod (pos. 7) to the Anchor Bracket on the column (pos. 9). Ensure that the Automatic Locking Pins are locked securely.
4. Connect the Connector Rod (pos. 7) to the Anchor Bracket of the Duo Jib of the Duo Jib (pos.5). Ensure that the Automatic Locking Pins are locked securely.
5. Lock the middle section securely with the fixing lock (pos. 8).
6. Mount the end section (pos. 4) and tighten securely with the end section lock (pos. 18, photo 3).
7. Attach the Counterweight Triangle (pos. 3) to end section.
8. Connect the parallelogram rod (pos. 19) to middle section and counterweight triangle. Ensure that the connection pins (pos. 1 and 17) connect correctly.
9. On the lower connection of the front section (pos. 14), mount, High / Low Rig (pos. 13). Ensure that locking lever (pos. 12) is locked securely.
10. Connect the Platform (pos. 10, photo 3) to High / Low Rig. Ensure that locking lever (pos. 11) is locked securely. Maximum Payload capacity incl. 2 persons = 220kg / 485 lbs. For other versions see the following pages.
11. Ensure that all connections are locked and tightened correctly.

No more than two counterweights should be loaded whilst the platform is unloaded. **As a general rule of thumb, for one person on the platform attach 4 or 5 counterweights, for two persons on the platform attach 8 or 10 counterweights.**

When operating the Duo Jib attention must be paid when mounting and dismounting the platform.

By two-man operation, remove the extra counterweights before one person dismounts i.e. no more than four or five counterweights should be left connected. Before the second person dismounts, reduce the amount of counterweights to three.

It is not recommended to drive the Duo Jib when the platform is unloaded and counterweights are attached. At all times beware correct balance by sufficient counterweight. To prevent an uncontrolled dropping of the MAGNUM column, (since year of manufacture May 2009) while using a Duo-Jib, a catch screw nut, which does not carry in normal operation, is built-in. It takes over the carrying function as a safety element at a possible failure of the piston stroke mother. However, it is not appropriate for driving the column. An occurred intervention of the catch screw nut can be closed from the following:

- Changed driving noise of the piston stroke column (loud, metallic)
- Increased and further disconnection of the control with the error messages "Err Nr.9".

In this case, the operation of the MAGNUM Dolly with Duo Jib immediately has to be terminated and the defect must be repaired! To do so, please contact the manufacturer.

Picture: Duo Jib Platform upper connection

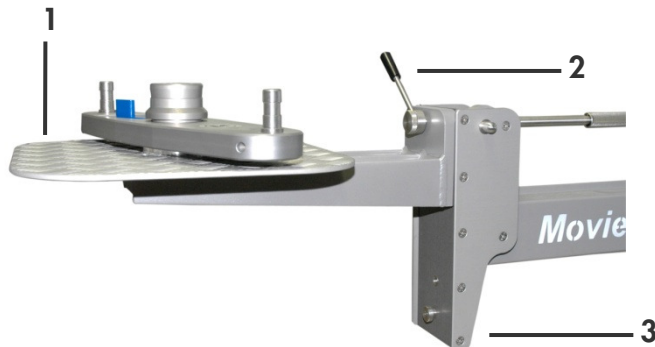

- 1. Platform
- 2. Locking Lever and Bolt for Platform
- 3. Front section

1. Connect the Platform (pos. 10, photo 3a) to the upper connection on the Front Section (pos. 14, photo 3a) as shown. Ensure that the Locking Lever and Bolt (pos.11, photo 4a) are tightened correctly.
2. Ensure that all connections are locked and tightened correctly.

Maximum Payload capacity incl. 2 persons = 250kg / 551 lbs

Picture: DUO Jib Platform lower connection

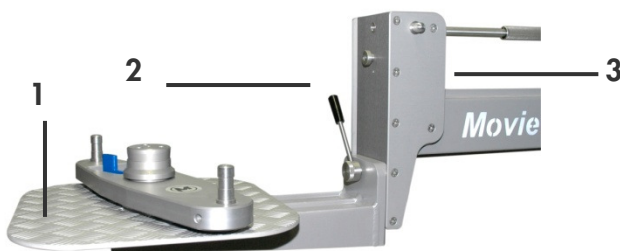

- 1. Platform
- 2. Locking lever and bolt for platform
- 3. Front section

1. Connect the Platform (Pos. 10) to the lower connection on the Front Section (Pos. 14) as shown. Ensure that the Locking Lever and Bolt (Pos. 11) are tightened and locked securely.
2. Ensure that all connections are locked and tightened correctly.

Maximum Payload capacity incl. 2 persons = 250kg / 251 lbs.

Picture: Duo Jib platform with high/ low range

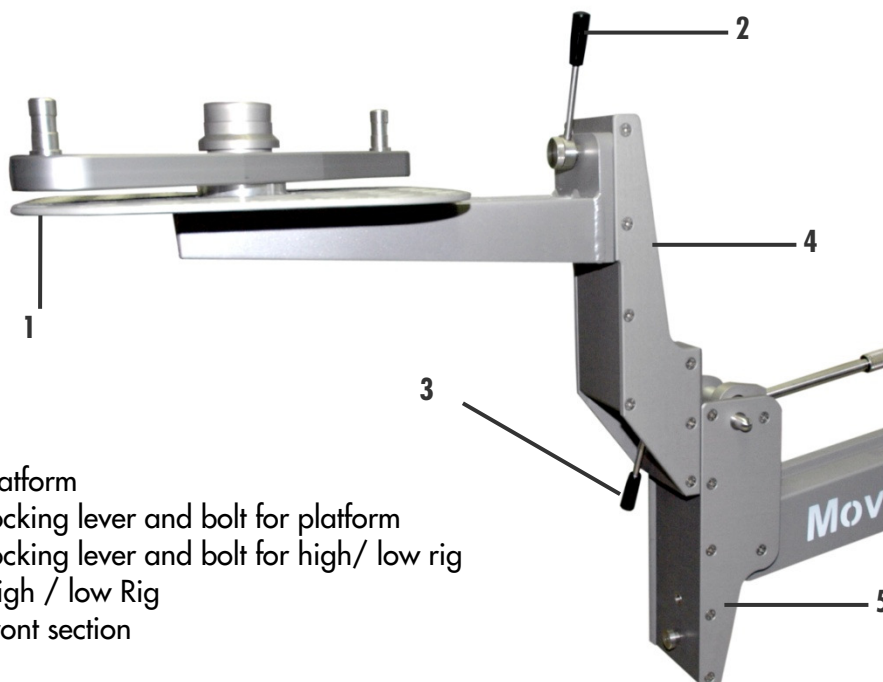

1. Platform
2. Locking lever and bolt for platform
3. Locking lever and bolt for high/ low rig
4. High / low Rig
5. Front section

1. On the upper connection of the front section mount high/ low rig as shown. Ensure that locking lever and bolt is locked securely.

2. Hand screw bolt (pos 3) into the whole (pos 2).

3. Connect the Platform to High / Low Rig as shown. Ensure that locking lever (pos. 3) is locked securely.

a. Ensure that all connections are locked and tightened correctly.

Maximum payload capacity incl. 2 persons = 200kg / 440 lbs.

Picture: High/ low rig



1. Bolt
2. Threaded whole

When using the high/ low rig as High Rig it is necessary to hand screw the Bolt (pos. 1) into the Threaded Hole (pos 2).

Part II – The control of the MAGNUM Dolly

Instruction Manual
Programming Overview
Software version: 1.6 / 23. 11. 2009

Mode 0 - storage of upper and lower position

This mode will allow you to limit the manual working range top/bottom of the dolly.
 In this mode there are no programmed moves possible, that is why it is originally named "0"
 There will be no reaction by pressing any keys.
 Therefore there is no reaction by accidental pressing of any key.
 The dolly will ramp down at the set limits.

Keypad layout:	
REC + F1	Actual position will be set as top limit
REC + F2	Actual position will be set as bottom limit
GO + F1	Top limit will be deleted, dolly extend to the fullest
GO + F2	Bottom limit will be deleted, dolly retract to the fullest
RESET	Allows you to make moves exceptionally outside the set limits

The 4 program possibilities can be used in any different sequences, as long as you pay attention to the following points:

- Programming a top limit below an already set limit is logically not possible, and vice versa.
- Position 000 mm cannot be set as top limit, at the same time the max position cannot be set as bottom limit.

The actual programmed status will be permanent shown on display (e.g. table display)

When dolly is switched off the values will be stored. When the dolly is switched on, or at change of any mode to mode „0“, outside of the limits the user will be asked to move the column back into range:

Go below high limit (XXX mm)! respectively Go above low limit (XXX mm)!

The opposite direction of the range limits will be initially blocked.

Display at switch on

After switch on or change of any mode into **mode „0“** the display will show one of the 4 following lines:

If **no limits** are set:

No limits stored, press REC+F1 for high, REC+F2 for low limit

If only **bottom limit** is set:

Low limit XXX mm, press REC+F1 for high limit or GO+F2 to delete low limit

If only **top limit** is set:

High limit XXX mm, press REC+F2 for low limit or GO+F1 to delete high limit

If **top and bottom** limits are set:

Low limit XXX mm, high limit XXX mm, GO+F1 to delete high limit, GO+F2 to delete low limit

Leaving the range of limits:

If it is required during operation to leave the limited range simply **press and hold the RESET-key**. As long as the Reset key is pressed the limits are without function.

As soon as the Reset key is released the column can be brought back in direction of the limit range set. Further you will see the following line in the display:

Go below high limit (XXX mm)! respectively Go above low limit (XXX mm)!

Mode „0“: Overlook display messages

OPERATION STATUS	DISPLAY "RUNNING" LINES
No limits stored	No limits stored, press REC+F1 for high, REC+F2 for low limit
Only top limit set	High limit XXX mm, press REC+F2 for low limit or GO+F1 to delete high limit
Only bottom limit set	Low limit XXX mm, press REC+F1 for high limit or GO+F2 to delete low limit
Both limits set	Low limit XXX mm, high limit XXX mm, GO+F1 to delete high limit, GO+F2 to delete low limit
Unit after switch on above top limit	Go below high limit (XXX mm)!
Unit after switch on below bottom limit	Go above low limit (XXX mm)!
By entering values no end switch passed yet	Pass upper or lower position indicator to enable programming!

Reason and position of proximity sensor:

Both proximity sensors (normally an absolute position indicator) will prevent the column to hit at all possible occasions the mechanical limits (top or bottom) of the column (e.g. the initial switch on after changing the hand control).

In fact the position of the column is stored after switch off, but the electronics will have no indication of using the emergency switch or exchange. In order to assure the proper operation the control has to get a feedback right after switch on about the absolute position of the column.

That is why on each side there is a proximity sensor is placed 11cm before the mechanical stop.

Position bottom sensor: 110 mm from bottom end stop

Position top sensor: 566 mm from top end stop

Without passing one of these sensors there will be no retrieval of programming function!

The display will show:

Pass upper or lower position indicator to enable programming!

Until one of the sensors will be passed!

A passing move of the sensor will basically happen when moving the column down passing 110mm, or moving the column up passing 566 mm (see mm value in display).

Mode 1 - storage of max. 30 positions

This mode will allow the user to program up to 30 fix positions in sequences.

These programmed positions can be called up always in the same sequence (forward and reverse) With each programmed position the individual speed and ramp will be stored.

Up to 30 positions can be stored.

By changing into a different mode the whole setting will be stored and will be always available.

Keypad layout:	
REC for min. 3 sec	Setting reference point (starting point) of the position sequence. At the same time all prior stored positions will be deleted
F1	Setting a target point after manual move
F2	Ending the setting procedure after entering 1 -30 target points
GO	Start move to reference point, or next target point
GO + F2	Start move to previous target point (sequence in return)
RESET	Immediate abortion of a programmed move (Emergency stop!!!)

Display after switch on:

After switch on or change into mode 1 the display will show one of the following messages:

If no target points are stored:

NO TARGET POINTS STORED, 30 FREE, PRESS REC 3S TO STORE REFERENCE POINT.

If target points are stored (e.g. 4):

04 target points stored, 26 free, move to next target, press F1 to store, F2 to terminate programming

Program can be used, see program call up, point 2

Programming procedure (example for 4 target positions):

1. Initially the column has to be moved into the desired reference/starting position. This position will be stored if the REC key is pressed for min 3 sec. This action is confirmed in the display.
Reference point stored, 30 target points free, move to target and press F1 to store .
2. Now move the column to the first target point and choose at the same time the desired speed. In order to keep the move easy the highest reached speed for the move will be stored. To store the first target point press the F1 key. The display will show now:
01 target points stored, 29 free, move to next target, press F1 to store, F2 to terminate programming
3. The procedure in no 2 can be repeated up to 29 times, after storing 4 positions the display will show:
04 target points stored, 26 free, move to next target, press F1 to store, F2 to terminate programming
4. To end the storing procedures please press the F2 key.
The display will show now:
Programming completed, 04 target points stored, press GO to move to reference point
5. The programming procedure is finalized.

To call up the program simply press the GO key to move the column to the reference point, please see program procedure no 2.

Program call up (e.g. 4 target points):

1. After switching on respectively choosing mode 1 the following message will be shown in the display:
04 target points stored, press GO to move to reference point
2. By pressing the GO key the column will move to the reference/starting point, the display shows:
Approaching Reference Point (XXX mm) press RES to stop
3. After reaching the reference point the display shows:
Reference point reached, press GO to start 1st target move
4. By pressing the GO key again the move to the first target point will be initiated, the display shows now:
Approaching Target #01 (XXX mm) press RES to stop
5. After reaching the first target point the display will show now::
Target point # 01 reached, press GO to move to next target or GO+F2 to go to last target
6. By pressing repeatedly the GO key the column now to the next target points (repeat point 4-5).
Should the column be moved to a previous target point simply press the GO + F2 Keys.
This may be helpful in order to reach a previous camera position.
In this example with 4 target points the display will show after reaching all points the following message:
Final target point # 04 reached, press GO to return to reference point or GO+F2 to go to last target
7. The program has now reached the end, and by pressing the GO key once again the column will go back to the reference/starting point.
By pressing GO+F2 the column will move back to the last target point. (in the example at point 3).

PLEASE NOTE: In order to assure the correct function you have to prior programming or call up a program pass a end switch (please see mode 1, proximity sensor).

If that is not the case the display will show the following message accordingly:

Pass upper or lower position indicator to enable programming!

Mode 1: Overlook display messages

OPERATION STATUS	Display "running" lines
No positions entered	No target points stored, NN free, press REC 3s to store reference point.
Reference point stored	Reference point stored, 30 target points free, move to target and press F1 to store
1-29 positions stored, not yet pressed F2	NN target points stored, NN free, move to next target, press F1 to store, F2 to terminate programming
1-30 positions stored, F2 pressed	Programming completed, NN target points stored, press GO to move to reference point
Column moves to reference point	Approaching Reference Point (XXX mm) press RES to stop
Reference point reached	Reference point reached, press GO to start 1st target move
Column moves to target point	Approaching target # NN, XXX mm), press RES to stop.
1. until next to last target point reached	Target point # NN reached, press GO to move to next target or GO+F2 to go to last target.
Last target point reached	Final target point # NN reached , press GO to return to reference point or GO+F2 to go to last target
Move abortion thru Reset key	MOVE STOPPED!!
Program try without passing the proximity switch	Pass upper or lower position indicator to enable programming!

Mode 2 - storage complete drive up to 4 Min. 20 Sec.

This mode allows you to record and store complete moves up to 4m20s in length incl. all speed changes and pause times. The position of the column will be captured and stored each millisecond. The here for required storage space will limit the time frame to 260 seconds.

By changing into a different mode or turning off the whole setting will be stored and will be always available.

Keypad layout:	
REC for min. 3 sec	Setting reference point (starting point) of the position sequence.
1. move the zoom switch after REC 3 sec.	Start to record the move
F2	Stop record, column must stand still
REC + F2 min. 3 sec.	Delete a stored move
GO	Start move to reference point, or next target point
RESET	Immediate abortion of a programmed move (Emergency stop!!!)

Display after switch on:

After switching on or change into "mode 2" the display will show one of the following 2 messages:

If no move is stored:

NO MOVE RECORDED, PRESS REC 3SEC TO START RECORDING

If move is stored:

Move stored, XXXs , press GO to go back to reference point or 3 sec REC+F2 to delete move

A stored move can be initiated (e.g. program call up) or can be deleted by pressing REC + F2 for 3 sec.

Programming procedure:

1. Initially the column has to be moved into the desired reference/starting position.
This position will be stored if the REC key is pressed for min 3 sec.
This action is confirmed in the display.
Reference Point stored, press zoom switch to start recording!
2. To start record simply move the zoom switch to initiate the move.
As soon as the recording started the display shows continuously the stored time as well as the left over recording time (example for 12 sec.):
Recording move, 012 sec, time left 248 sec, press F2 to terminate!
3. To end recording the F2 key must be pressed while column stands still
(stored move must end with a stop).
The display will show then (account move time 1 min 35 sec.):
Move stored, 095 sec, press GO to go back to reference point
4. The programming procedure is now finalized.

To call up the program simply press the GO key to move the column to the reference point, please see program procedure no 2.

Program call up (e.g. for move 1 min 35 sec):

1. After switching on respectively selecting the mode 1 it will display the following message:
Move stored, 095 sec, press GO to go back to reference point
2. By pressing the GO key a move to the reference point will be started.
The display shows:
Approaching Reference Point (XXX mm) press RES to stop
3. After reaching the reference point the display shows:
Reference point reached, press GO to start recorded move
4. By pressing the GO key once again the recorded move will be started.
The display shows:
Playback running, time left, 092 sec, press RESET to abort
As long as the column is in motion, the running time left will be displayed.
At this point the user basically has no need to interfere, but for safety reasons he should not leave the hand control un-attended.
The move can be aborted at any time by pressing the RESET key.
5. After the stored move has ended or the abortion of the move the display shows:
Playback over, press GO to return to reference point
6. The programmed move ended now.
To repeat move simply press the GO key again (to return to the reference point).

PLEASE NOTE: In order to assure the correct function you have to prior to programming or calling up a program, the end switch needs to be passed (**please see mode 1, proximity sensor**). If that is not the case the display will show the following message accordingly:

Pass upper or lower position indicator to enable programming

Mode 2: Overlook display messages

OPERATION STATUS	Display "running" lines
No moves entered	No move recorded, press REC 3s to start recording
Reference point set, column stands still	Reference Point stored, press zoom switch to start recording
Record started, column still stands	Recording move " XXX s, time left XXX s, press F2 to terminate!
Record started, column moves	Recording, time left XXX s, press F2 to terminate!
Record stopped, respectively status after switch on	Move stored, XXX s, press GO to go back to reference point
Column moves to reference point	Approaching Reference Point (XXX mm) press RES to stop
Column stand on reference point	On Reference Point, press GO to start recorded move
Play move	Playback running, time left , XXX s, press RES to abort
Stop or aborted move	Playback over, press GO to return to reference point
Abortion with the RESET key	MOVE STOPPED!!
Program try without passing the proximity switch	Pass upper or lower position indicator to enable programming!

Mode 3 - operation via serial interface

This operation mode is intended for external control possibilities of the MAGNUM dolly via an external system (e.g. PC or Motion control system).

This operation mode is not implemented yet, therefore the display shows:

No serial connection!

However, manual moves without limitation are possible.

Display of operation hours:

By pressing the **F2** key during the boot of the system the display will show the following:

Running Time: XXXXX h

Motor Time: XXXXX h

Press GO to continue

The first information on the display is the sum-up of the running time of the control electronics since the dolly was first built.

The second information shows the sum-up of the hours the column actually has been moved. This helps to determine the operational time of electronics and mechanics. The counter only shows full hours in max of 5 digits, but internally the time will be stored up to seconds and this will be stored at every switch off of the system.

After pressing the **GO** key the hours will disappear in the display. The column will go into operational mode and to the display accordingly.

Error messages scheme and error correction power supply 48 Volt

Error message what needs to be checked and done?

- No.1**
- let the motor cool down, and/or remove the damping cover of the motor to let the motor cool down faster.
 - Error prevention: please note and follow minimum payload,
 - Minimum 80 kg**
 - Optimum 150 kg
 - Maximum 250 kg
- Check for possible contact thermo resistor interruption.
 Check the connections from motor cable to socket board at tightening plate (plate will be visible when electronic module is removed) for proper connection and for possible damages.
 Connectors have to be clicked solid in position.
- No.2**
- Electronic module exchange.
- Error in system can only be rectified by the manufacturer
- No.3**
- Function control of proximity switch via LED display on electronic board.
- The LED display control is right below the electronic display on the top board. It is a row of 6x SMD- LED's.
 For that purpose please remove the electronic cover.
- LED No. 5 – lights up (red) if top proximity switch is activated.
 Position of column from 683 to 566 mm,
 Watch the information on display.
- LED No. 6 – lights up (red) if bottom proximity switch is activated
 Position of column from 000 bis 110 mm,
 Watch the information on display.
 In case the LED stays turned off in the proximity switch range, a defect is confirmed.
 A picture of board with LED can be found on page 43.
- Check proximity switch, possibly the proximity switch is defective or the socket board is disconnected respectively the contact proximity switch cable is interrupted.
 Check contacts respectively exchange proximity switch.
- No.4**
- Please do not move the zoom switch of hand control right after switching on of the system. Electronic will perform a self diagnostic for approx. 2 sec.
 A definite clicking sound will appear when self diagnostic is finalized.
 - Potentiometer of zoom switch not in the center spot.
 Spring of zoom switch maybe misaligned or broken.
 Adjust center spot or exchange spring.
 - Possible break in cable of hand control, exchange cable

- No.5** - No error code, number not in use!!!
- No.6** - Batteries discharged, currently below 17V, respectively 34V. Exchange both batteries for fully charged batteries (re-charged discharged immediately)
- Do not use flat batteries at all, otherwise you risk the damage of the cells (exhaustive discharge).
(Also see note MAGNUM batteries)
- No.7** - After reconnecting the electronic this error may not occur anymore
- If error repeatedly occurs then the electronic module needs to be replaced, defect in unit.
- No.8** - possible interruption of contact in brake cable,
check connector on motor cable and socket board for proper connection.
Fix possible loose contact.
- Otherwise like error code no.7
The electronic module needs to be replaced, defect in unit.
- No.9** - Check both batteries for discharge and exchange accordingly for new ones.
- Check the encoder, maybe loose on shaft. Encoder does not turn, tighten screws on shaft.
- Possibly defective encoder or connector on encoder cable wrong positioned.
Re-position, re-connect connector properly (at the last 2 points when operating the zoom switch moves without control) then the electronic will stop the system and show error code no.9.
- Column hit an obstacle and electronic stops the system.
Remove obstacle and possibly exchange the 30A fuse.
- Drive belt tension not enough. Belt slips, readjust belt tension.
- Possible error in electronic unit itself. Error code will appear right away after touching the zoom switch, even though column is not moving, electronic module needs to be replaced.
- No.10** - Main fuse 30A exchange, possibly defective fuse.
Exchange, if error occurs again then electronic module needs to be exchanged, error in electronic.
- No.11** -Check motor, possibly defect.
Motor exchange
- Column blocks, possibly hit an obstacle.
Please ensure free motion on top and bottom track
- No.12** - Check hand control, error in hand control or hand control cable.
Possibly exchange hand control or cable.
- No.13** -Check hand control potentiometer.
Possibly readjust or exchange potentiometer

Movie Tech MAGNUM Dolly control unit – overview error messages

error No.	Control display			Error description	Reaction of the dolly
	Code	Line 1	Line 2		
1	ERR	No. 1: Hot	Motor too hot, try again later (10 min.)!	Motor temperature to high or cable link to thermo sensor broken	stop with ramp
2	ERR	No. 2: 12 Volt	Supply 12V defective, device must be changed	Supply 12V defective	abrupt emergency stop
3	ERR	No.3: EndSw	Both Position indicators active, check indicators and column wiring	Both Position indicators active at the same time	stop with ramp
4	ERR	No.4: Accel	Don't touch zoom switch during self test/ check hand control	Hand control has been used during set up	no power-up
5	Free, no use				
6	ERR	No.6: LoBatt	Battery voltage too low, please recharge batteries	Battery voltage too low	stop with ramp
7	ERR	No.7: Brake	Brake supply out of control, device must be changed	By mistake, voltage on brake despite missing control signal	abrupt emergency stop
8	ERR	No. 8: Brake	Brake supply voltage low or brake not connected	Brake supply voltage low or brake not connected	abrupt emergency stop
9	ERR	No. 9: PosERR	Excessive Position Error, column mechanically blocked, digital encoder or device defective. Check drive belt and batteries!	Deviation from normal condition	abrupt emergency stop
10	ERR	No. 10: Power	Power Stage Supply Voltage too low, check 30A Fuse! If fuse OK, device must be changed	Power Stage Supply Voltage too low at end position; fuse or end position defect	abrupt emergency stop
11	ERR	No. 11: Motor	Excessive Motor current, column blocked or motor defective	Motor current too high	abrupt emergency stop
12	ERR	No. 12: Cable	Hand control buttons out of order, check cable! Press zoom switch to start	Hand control buttons out of order	Note only, moving via tippler possible
13	ERR	No.13: Cable	Zoom switch value out of limits, check cable or change hand control	Zoom switch value out of limits	stop with ramp

Arrangement of controls on the electronic front

Emergency Button

To be used only in case of hand control emergency

Ramp control

- 1: Standard use 1 (Speed 100%)
- 2: Standard use 2 (Speed 80%)
- 3: Jib-application 1 (Speed 70%)
- 4: Jib-application 2 (Speed 60%)

Programming control

Mode

- 0: Storage of position/ Indication of operating hours
- 1: Storage of max. 30 single positions
- 2: Storage of a complete drive. Max. drive time 4 min. 20 sec.
- 3: No configuration

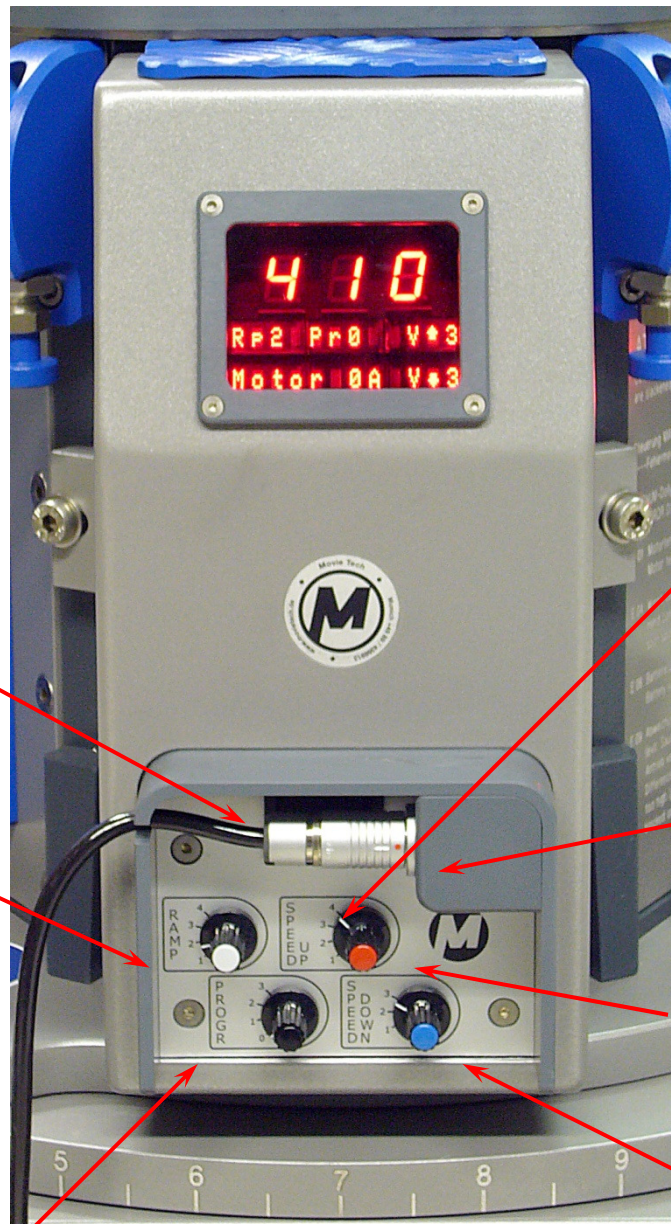

Control for top speed pos. „4“ „UP-movement“ max. speed in combination with hand control pos. „4“

Access for hand control

Speed control „UP-movement“

Speed control „Down-movement“

Explanation multifunctional display

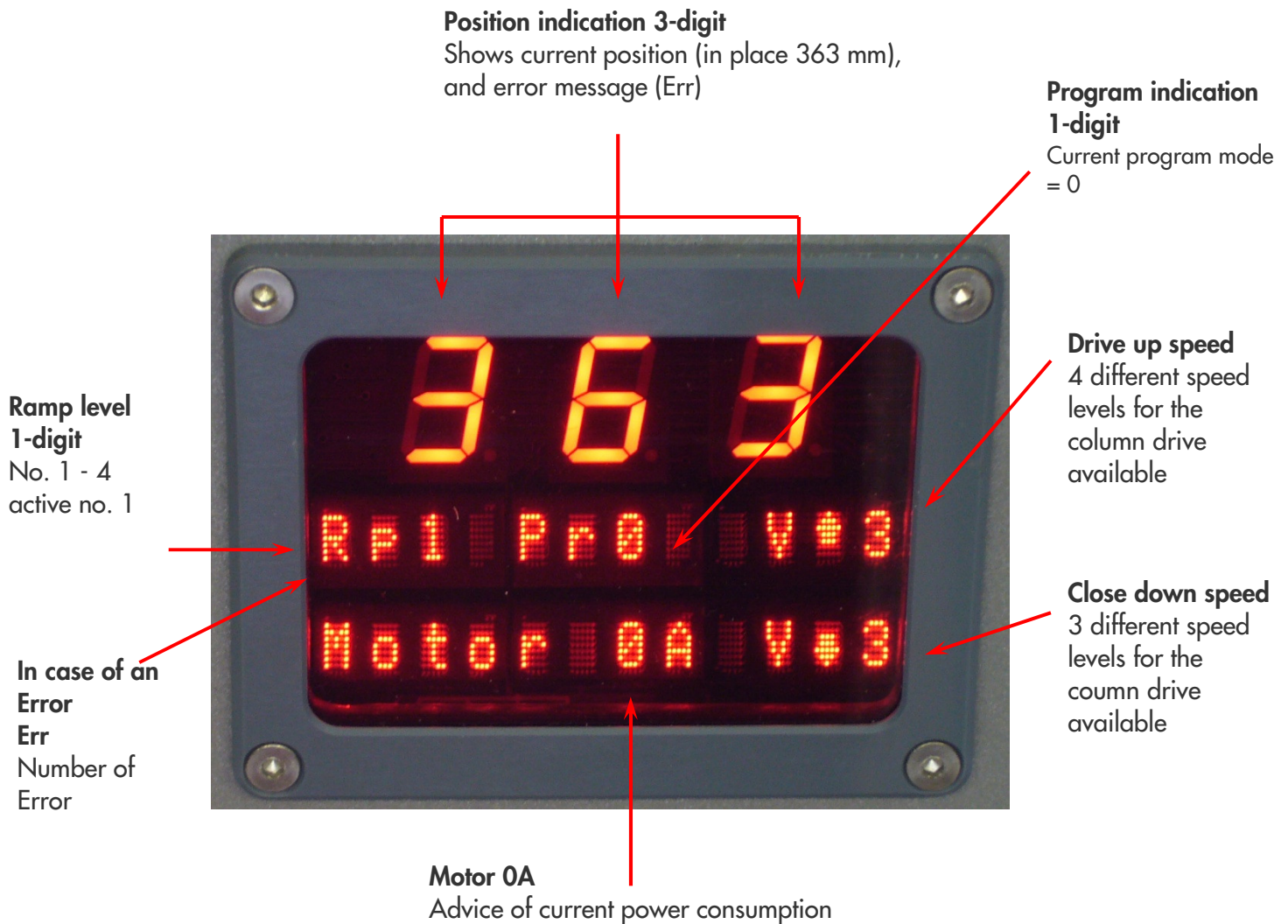

Control Unit

Start up

To switch on the dolly use the ON/OFF switch on the hand control. The red control light lights up.

After switching on wait 2 seconds as the system performs a self-test. During this time you should not depress any of the buttons. If you do, the system will consider this an error and will show "ERR Nr. 4" (see similar errors on page 30) on the display. Switch the dolly off again and switch on, do not touch the buttons during the self check time (2 sec.).

Manually operated drive

The speed of the column can be varied with the hand control zoom switch. You can further control speed by use of the following 4 speed selections (see picture):

1: Slow drive (30%)

2: Medium drive (60%)

3: Fast drive (100%)

**4: Adjustment on the electronic unit for separate up and down speed selection is active!
(Control for Speed up and down on page 33)**

With a voltage of 48 Volts in speed selection 4 and ramp selection 1 and UP speed selection in pos. 4 you may reach a maximum speed of around 2.5 seconds for a travel of 683 mm.

Picture: hand control

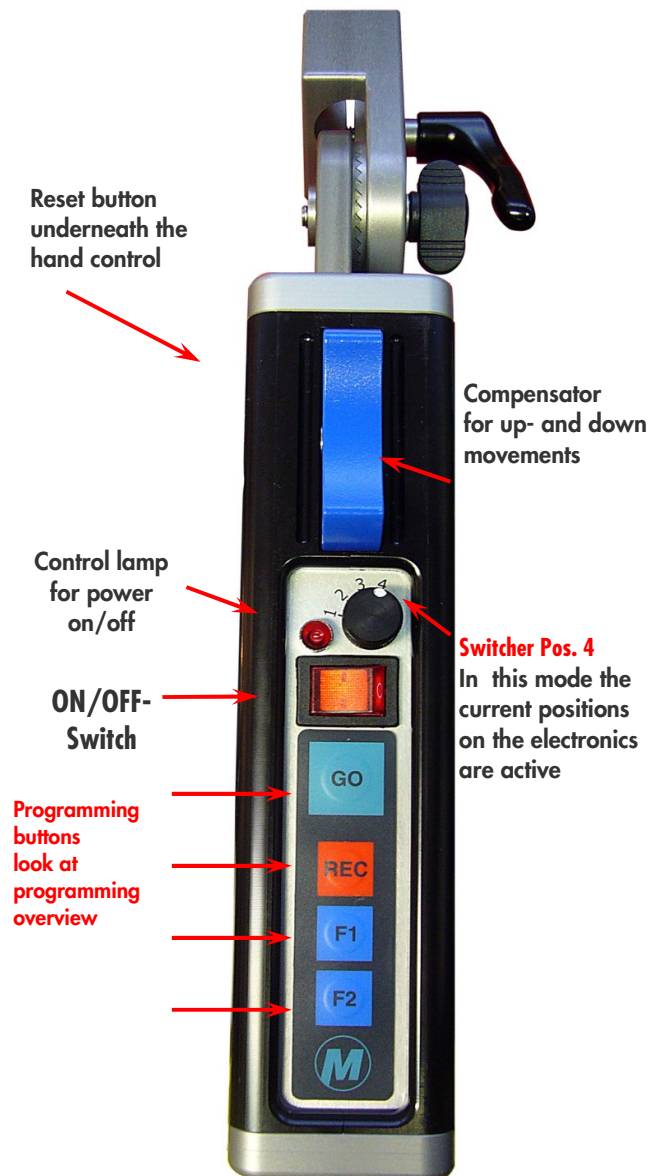

Ramp switch

The Magnum dolly has a 4 level ramp switch for changing the acceleration and braking behaviour of the column allowing to adapt the movement as closely as possible to the shooting requirements and different dolly setups.

You can select the following 4 operation ramps:

1. Standard 1 (speed-up 100%)

Very hard acceleration and abrupt stopping when you let go the zoom switch on the hand control. A smooth acceleration is only possible if you use the zoom switch on the hand control very delicately. This ramp is good for use with camera without an operator on the column.

Use with Duo Jib is not allowed!

2. Standard 2 (speed-up 80%)

Soft acceleration and braking for smooth stopping with 1 or 2 operators on the column when a quick stop by letting go the zoom switch is necessary.

Use with Duo Jib is not allowed!

3. Jib 1 (speed-up 70%)

For use with Jib arm. Acceleration is softer than in position 2. Absolutely smooth stop, especially useful for 2 persons on the column, requires a well trained operator to use the hand control.

4. Jib 2 (speed-up 60%)

Softest possible acceleration and deceleration. Even when you let go the handcontrol zoom switch suddenly, the column will stop smoothly. Best ramp selection for 2 persons on the column or use with Jib arm. It is not advised to use this ramp with a standard configuration as retardation of the starting and stopping do not allow direct control of the movement of the camera.

The 4 ramps can also be applied to the programmable modes. The ramps also affect the way the column stops when reaching the top end and lower end of column movement, not only the way it reacts when pressing and releasing the hand control zoom switch.

IMPORTANT: it is possible to switch ramps only when the dolly is switched off!

For technical reasons the ramp selector is recorded by the system only once when switched on, it is not possible to change ramps during operation, you must first switch the dolly off, change ramp and then switch the dolly on again.

Function of proximity switch

The Magnum Dolly has two end of range switches, positioned about 11 cm before the top limit and bottom limit of the column. If when you switch on the dolly, the column is close to one of the switches, then the column will be able to move initially only till it reaches the switch (please see pict. of LED on next page). This way the column cannot be driven over the top or lower limit when the recorded position at switching off does not correspond to the position of the column when switching on (e.g. after use of the emergency switch). Programmed sequences are also only possible when the column is within the end switch range.

Emergency override switch

The Magnum Dolly has an emergency override switch behind the socket where the hand control is connected to the Magnum. This allows to move the column up and down when there is a fault in the control system. The emergency switch connects the motor with current from the batteries releasing the electromagnetic brake when depressing the switch. It moves the column at high speed without the possibility of slowing down or acceleration.

IMPORTANT: AT TOP AND LOWER END POSITION THERE IS NO AUTOMATIC DECELERATION OF COLUMN MOVEMENT

If the column is moved with the override switch over the endposition (out of higher or lower range) a fuse will burn (see pict. on page 39) and the dolly will stop working. Out of this reason MovieTech strongly recommends to use the emergency override switch only in real cases of emergency.

SMD – LED advice on the board and function

SMD – LED on the main board underneath the display, to be seen when the cover for the electronic unit is detached.

Examples of information on LED

Picture 1

Green: Selftest has successfully been performed
Red: Lower end switch is active

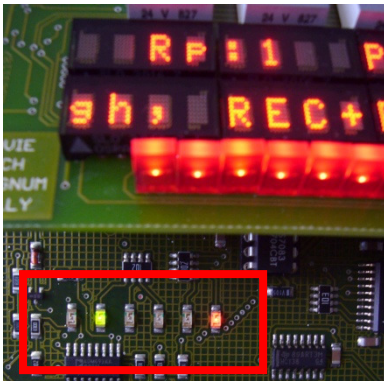

Picture 2

Green 1: Selftest has successfully been performed
Green 2+3 : Motorbrake is open

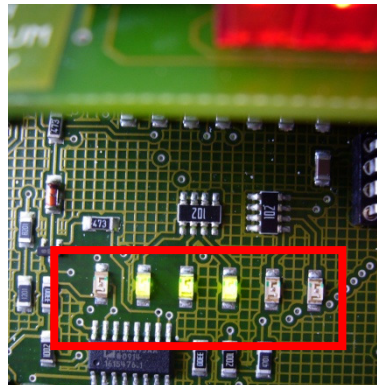

Picture 3

Green: Selftest has successfully been performed
Red: Top end switch is active

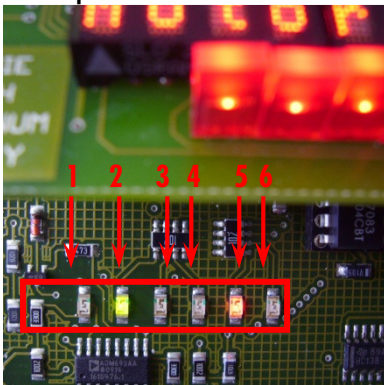

LED1 – lights up shortly when dolly is switched on

LED2 - self test of the electronic unit has been performed, after about 2 seconds it lights up and remains on.

LED3 – lights up green when the zoom control switch is depressed, the motor brake is open / switches off after about 3 seconds without any movement, the motor brake is on.

LED4 – lights up green when you depress the zoom switch, motor brake is open, switches off after about 4 seconds without movement.

LED5 – lights up red – top end switch is active – column within 683 - 566mm range (LED 6 is off)

LED6 – lights up red– lower end switch is active – column within 0-110 mm range (LED 5 is off)

Layout fuse

View of lower electronic control board

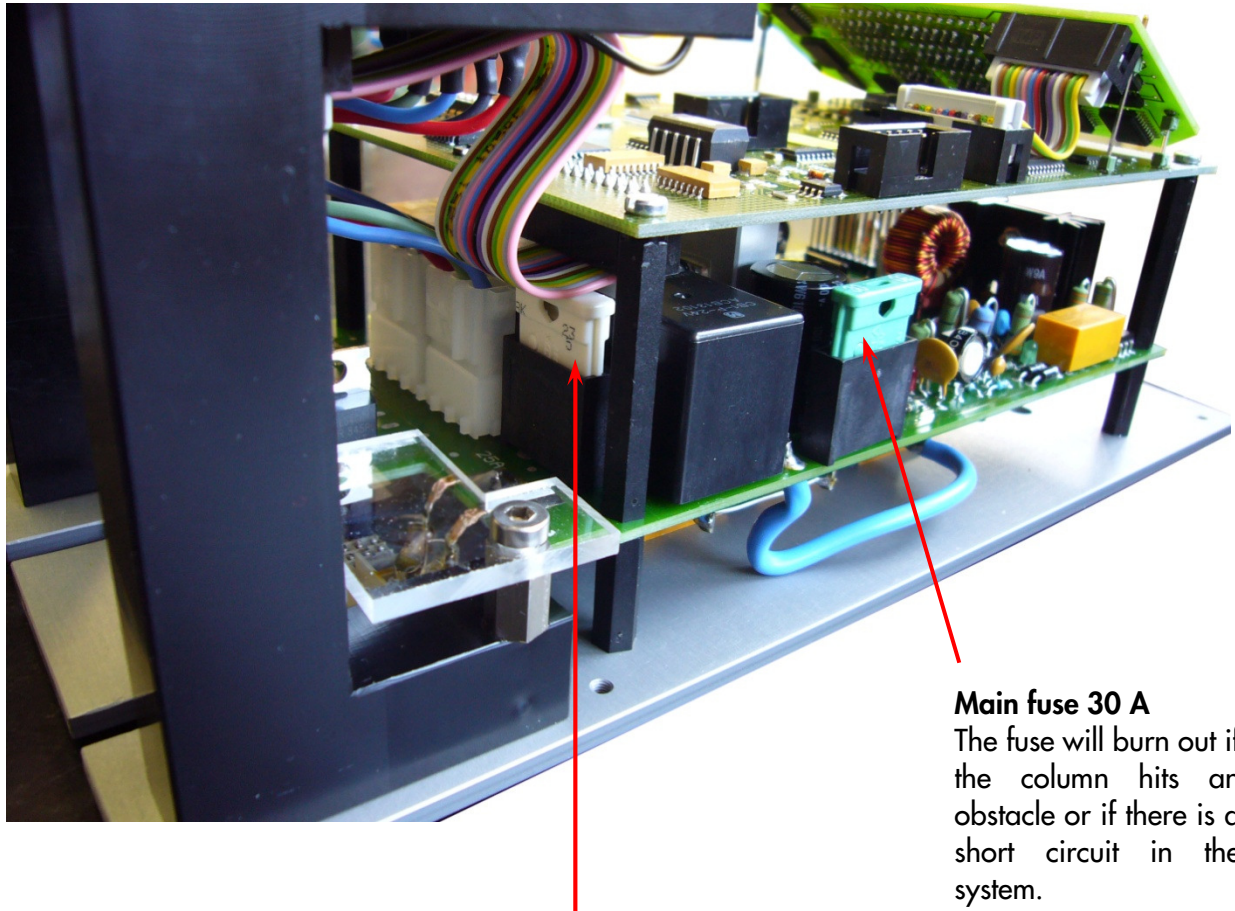

Emergency fuse 25 A

The fuse will burn out if the column hits an obstacle during operation with the emergency override switch.

Main fuse 30 A

The fuse will burn out if the column hits an obstacle or if there is a short circuit in the system.

Handling and care of MAGNUM batteries

The MovieTech Magnum-Dolly is operated with two 24 V batteries built up from four 6V-lead-acid-accumulators each. They deliver optimum capacity, but are (similar as car batteries) sensitive to deep discharge and lack of maintenance. They suffer irreversible defects by deep discharging and mechanical shocks.

Batteries which are well maintained can achieve a lifetime of 5 years and more.

The batteries are connected in series and supply 48 V DC to the control. Both batteries are identically stressed. The weakest 6V-cell in this configuration is determining the capacity of the complete set. As one faint cell brings the whole battery set down, always four good cells should be in one battery box.

Under normal conditions (with a load of approx. 150 kg = 330 lbs) more than 800 complete movements (up and down) are possible with one full set of batteries. Practical experience of shooting under normal conditions (12 – 16 hours / day and 4 – 5 days / week) shows that 2 weeks between recharging cycles are possible.

For trouble-free operation please consider:

1. Do not dump, throw or hit the batteries; move them with caution
2. Always change both batteries and use identically charged ones; do not insert batteries with less than 60% capacity (push test button and read "xx%")
3. In case the electronic shuts off during operation and displays „E06“, the batteries are discharged: Change both against fresh ones, don't continue to operate. Re-charge removed batteries and store them in charged condition, do not store discharged batteries for more than 5 days
4. You can keep batteries over a long period in the charger unit. It might be connected to power (to keep the batteries fresh) or not
5. Remove at least one battery from the dolly when the dolly is not used longer than one week from the column to interrupt the power cycle. Otherwise the control pulls always a little power and kills batteries within 4 – 5 months
6. We strongly recommend to change always all 4 cells in a battery when the cells are used over a period of 3 months or longer to avoid a slack in capacity. Only when the cells are new (and one is defective) a single cell change makes sense

Trouble shooting tips:

1. When the dolly stops and displays (--), the voltage is low. Normally one of the batteries is discharged. Test the battery capacity; remove batteries with less than 60% charge against fresh ones. Always use batteries with similar charging percentage.
2. The emergency button on the electronic front panel (see saw switch with arrows) has only two functions:
 - a. If the dolly is not retracted completely when it stops because of empty batteries („E06“) it allows for one-term retracting of the Magnum column
 - b. During servicing it allows for overriding the upper end switch to disassemble the gas springs.

Never use it to operate the column! This can cause damage to electronic and batteries! Retracting the column completely requires a load of minimum 80 kg (= 130 lbs) on it! Never retract the column completely without additional load (it has to move extremely hard against 3 strong gas springs inside the column)! Damages caused by faulty operation or disregard of these instructions are out of warranty!

Error messages power supply 110 or 220 Volt

The „Err – Lamp“ on the power supply unit shows a flash-code which is to be analyzed as follows:

- 1 blinks: left output stage is defective
- 2 blinks: right output stage is defective
- 3 blinks: total voltage is too low (eventually due to low input voltage)
- 4 blinks: overconsumption of current (dolly has an excessive consumption)
- 5 blinks: defective brake resistor

Light permanently on: battery mounted on dolly (besides the power supply unit no other battery is to be mounted on the dolly. In place of the second battery a short-circuit plug [Art.-Nr. 2020] must be mount

Manual for Charger Magnum Dolly 24/48 V – since 2004

After turning on the unit 4 steps will be processed:

- The unit recognizes a battery. At open exit the display will show the info: **OPEN**
- If a battery is attached the display will show **24 V** or **48 V**, understanding what type battery is attached.
- During the test period of approx. 10 sec. the charging current increases slow to its nominal value.
The red LED shows the charging procedure. Alternatively the display shows e.g.:
TEST/24V/0,7A/TEST/24V/1,2A
- After reaching the nominal charge current (approx. 2A at 48V, approx. 3.8A at 24V) it will be changed into regular charging mode.
Display shows e.g.: **LOAD/24V/3.5A**
- The battery will be charged until it reached the final top charge value 55V respectively 27.5V, the charge current will drop under 0.3A.
- Subsequently, the fully charged battery will be held at proper current with approx. 0.3A.
The green LED indicates the charge is complete.
Display shows: **FULL/24V/0.3A**

EC-Declaration of Conformity

Company MovieTech AG
 Martin Kollar Str. 9
 81829 München

We hereby certify that the following described machine in its conception, construction and form put by us into circulation is in accordance with all the relevant essential health and safety requirements of the EC machinery directive.

This declaration is no longer valid if the machine is modified without our consent.

Description of the machine: Dolly
Type of machine: MovieTech Magnum Dolly

Appropriate regulations: 98/37/EG
BGV C1 – for staging and production facilities for the entertainment industry
DIN 15999

Munich: June 21th, 2006



(Berthold Kastl, CIO)

MovieTech AG

Martin-Kollar-Str. 9 • 81829 MÜNCHEN
Tel. 0 89 / 43 68 91 3 • Fax 0 89 / 43 68 91 55
info@movietech.de



(Dipl.-Ing. Gunnar Flosbach, constructing engineer)

Manual - Charger for Magnum Dolly batteries Model from 2004 on

After turning on the charger, it will do four (4) steps to charge the batteries:

- Please use Charger just at the Charger Adapter Plate. With the Charger Adapter Plate, it is possible to install one or two batteries at the same time and charge them
- The charger checks if a battery is correctly connected or if a battery is out of order. If not the display will show **OPEN/0,0A**
- After connecting min. one battery and turning on the Charger, it will display **24V** and the test phase will begin
- During a testing time of approx. 10 sec., the charging current will be slowly raise to the optimum value. The red LED announces charging. The display shows alternating messages, e.g.:
TEST/24V/0,7A/TEST/24V/1,2A
- After reaching the optimum charging current (about 3,8A at 24V) the charger changes to regular charging. The display will show e.g.:
LOAD/24V/3,8A
- The batteries will be charged until the charging current falls below 0,3A at a voltage of 27,5V
- Finally, a conservation charging with 0,3A will follow.
- The green LED shows that the charging has been completed:
Display: **FULL/24V/0,3A**
- The batteries can remain in the charger until they will be needed



I What is required:



Motor (Art.-No. 20000214)



in tool kit case
Screwdriver,
Allen wrench SW 1,5 / 4 / 5
combi wrench SW10



as support (not included):
wire clip (diam. 5 mm)

II Removal of old motor

How to prepare the dolly:

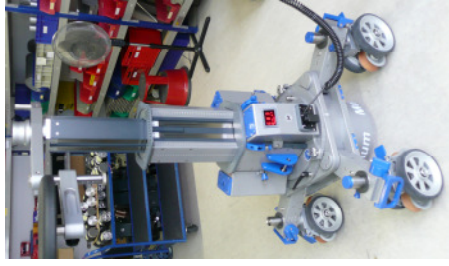

Extend dolly completely
(display shows 683)

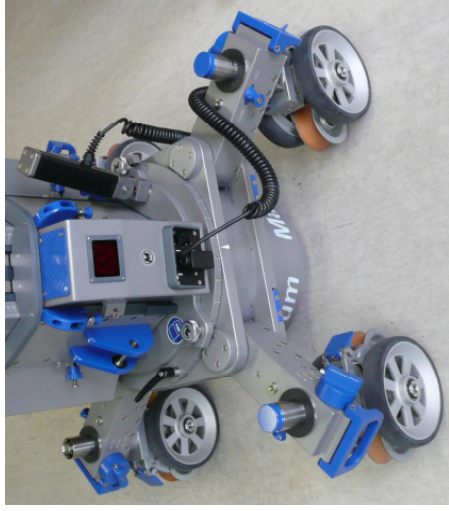

Press the brakes, put the wheels
in position as shown



Prepare 2 supports (approx. 250 and 180 mm high)

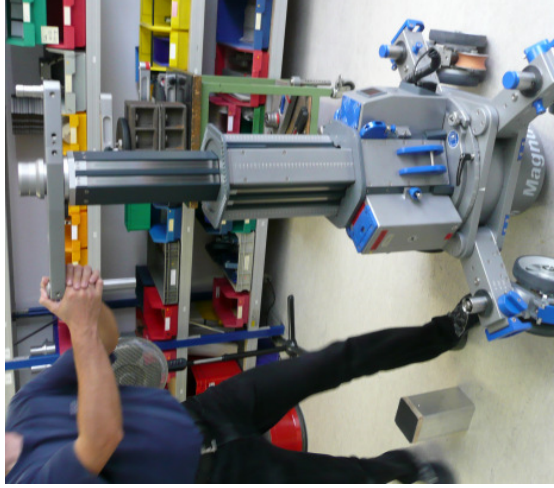

Put and lock turnstile mount as shown

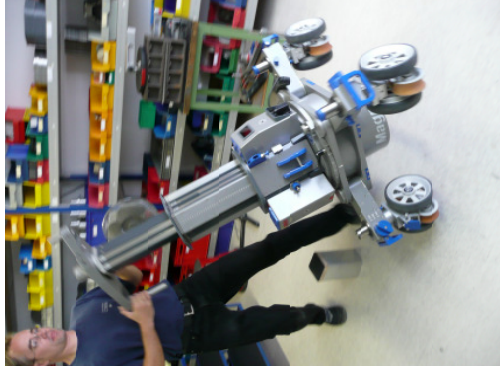
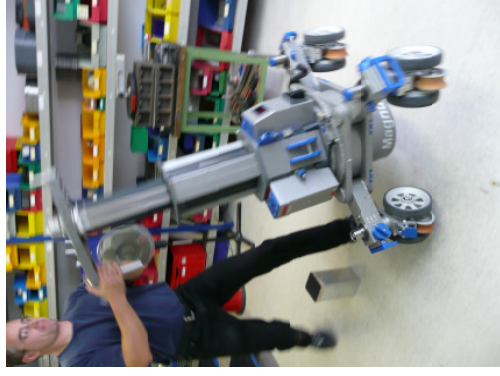
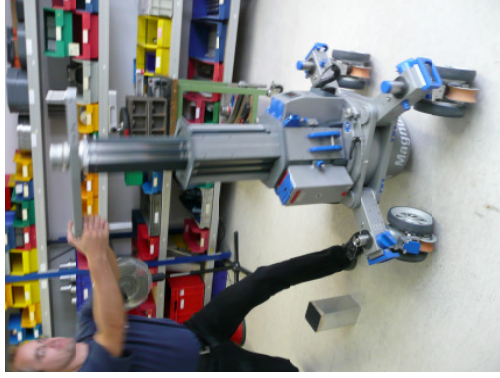

. . . pull with a tug, tilt the dolly and set it carefully horizontally down on 2 supports

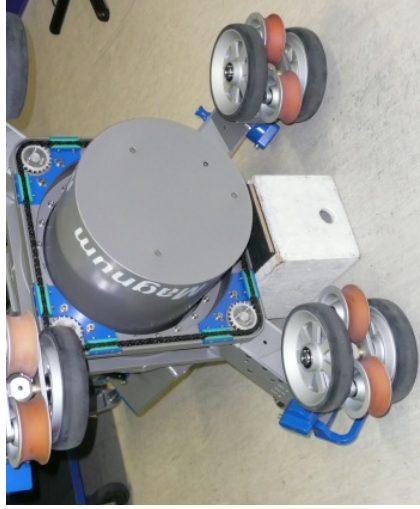

Position for motor change



Unscrew the noise reduction cover,



. . . remove it --->

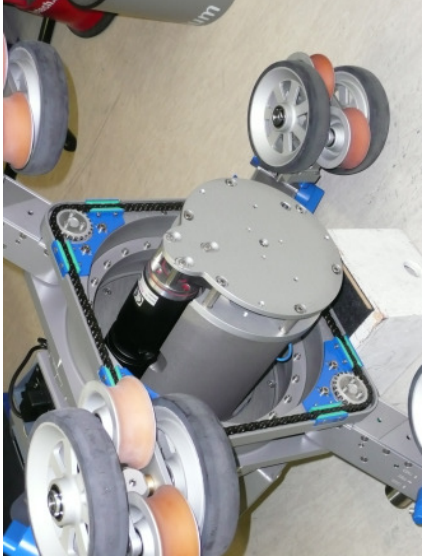

Now you have access to the motor



Support motor underneath pulley with screwdriver, remove 3 hexagon screws

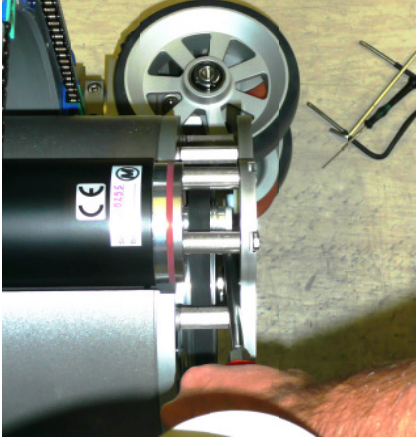

How to support (view from top)

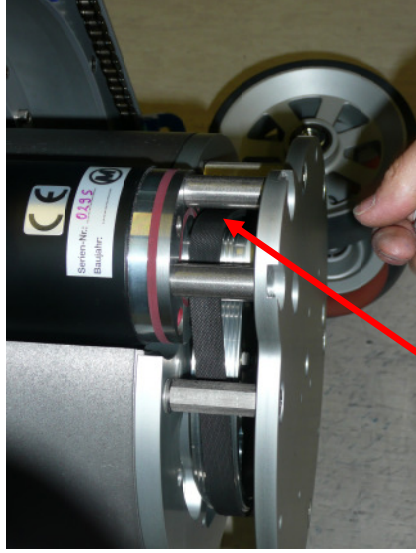

Remove screwdriver, belt is loose

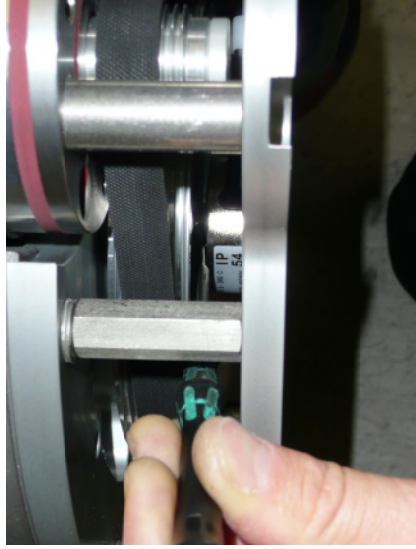

Loosen (do not remove!) two allen screws of encoder hollow shaft

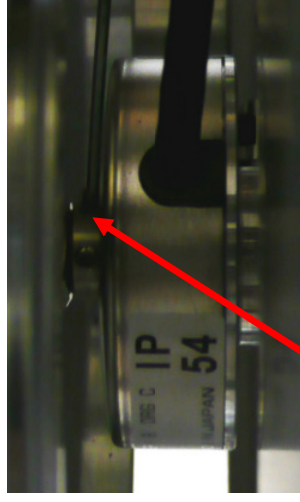

How to place the allen key 1,5



Unscrew cover plate,



... remove it,



... and



... place it on top of the wheel

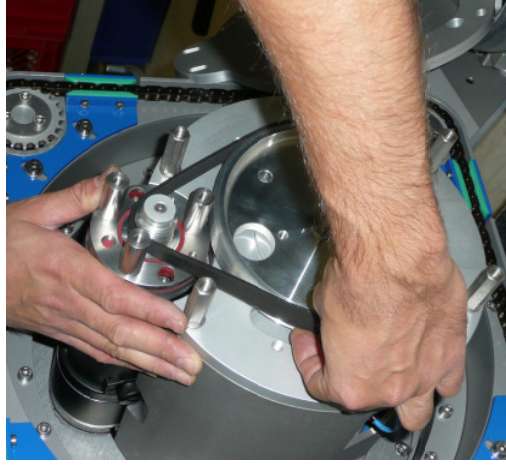

Push down motor, pull away

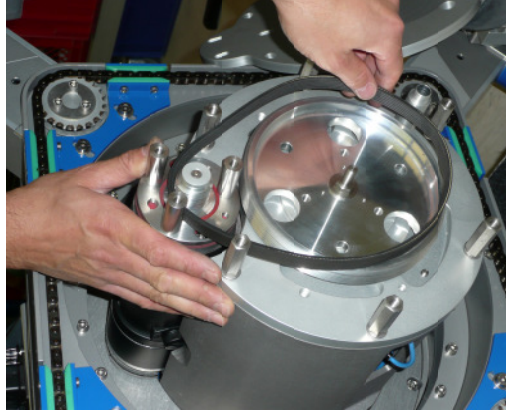

... belt.



Place wire clip as shown,



... carefully pull motor forward and set it onto clip.



Cautiously pull white plug in your direction (don't stretch the cable to avoid loosening



... of the inner plug behind the electronic), open the plug



... DONE!

III Install the new motor vice versa. Please consider:

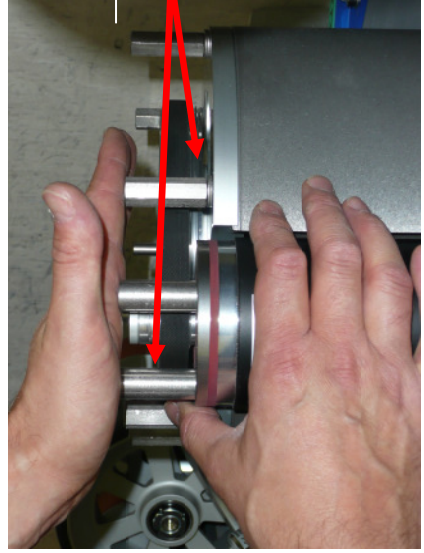

Place the belt parallel to the cover plate (both pulleys allow for 3 belt positions)

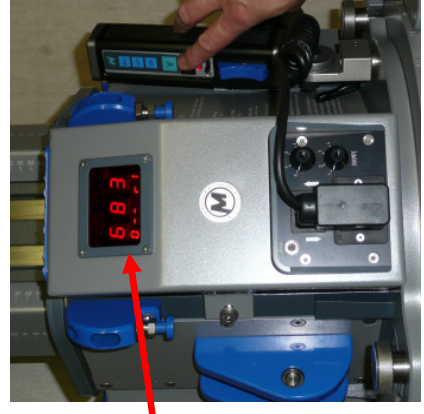

After connecting the new motor: Switch on electronic kit but do not move; reading should be „683“ (OK); if not: Check plug connection.