

# The Rocker Dolly Technical Specifications

Scale for setting steering angle



... easily transported in a case



## Variable steering geometry

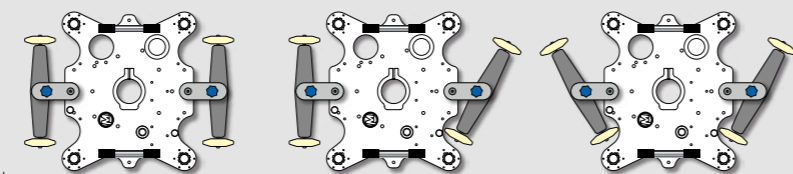

Short wheelbase

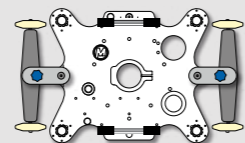

Long wheelbase

The long wheelbase is ideally suited for shots in very narrow locations such as train and airplane aisles or the like.

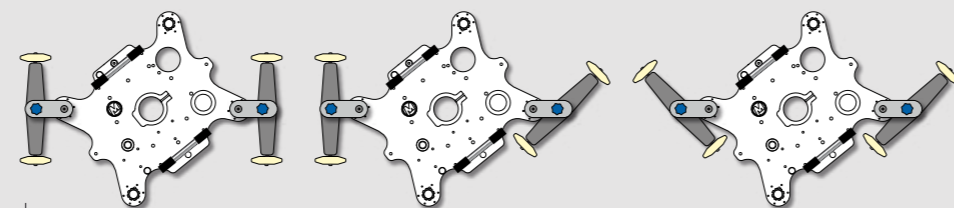

Diagonal wheelbase

## Sizes and weights

### Long wheelbase

Length: 72,45 cm (L)  
Width: 51,8 cm (B)

### Short wheelbase

Length: 64,45 cm (L)  
Width: 43,8 cm (B)  
Height: 8 cm

Weight: approx. 12 kg

Packaging dimensions: 63 x 55 x 22 cm

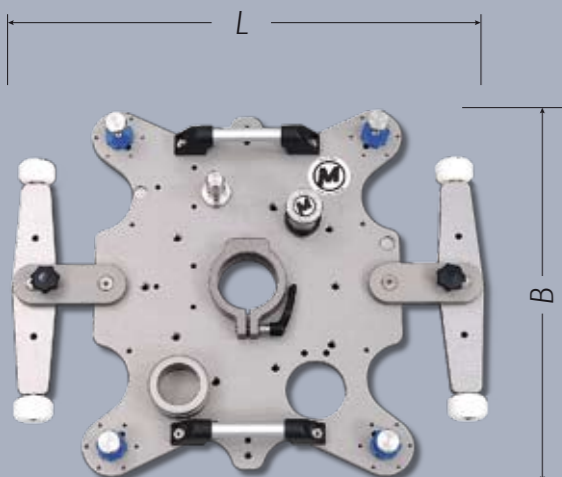

Unlimited freedom of creativity



## The Rocker Dolly



Movie Tech AG  
Martin-Kollar-Str. 9  
D-81829 München

Tel: +49 (0) 89/43 68 91 3  
Fax: +49 (0) 89/43 68 91 55  
e-mail: info@movietech.de

[www.movietech.de](http://www.movietech.de)

Technical details are liable to variations • Copyright by Movie Tech AG



# The Rocker Dolly System

The best time to appreciate the true size of the Rocker Dolly is in unusual situations! An ultra-lightweight dolly with an extensive range of possible applications – developed to put your ideas into the scene even more effectively. Precise cornering maneuvers can be accomplished quickly and easily, right down to close-up range movements, which may be repeated thanks to a special steering system. Its low weight and wide range of accessories make this performer into an essential instrument for motion shots – fascinating perspectives are guaranteed!

## The Rocker Dolly basic set

The basic set includes the following adaptations:

- Rocker Dolly base
- Table wheel set
- Small Euro mount (ABC Products) 80 mm
- Clamp for Euro mount
- Support for 4-way leveling head
- 2 carry handles
- Seat connection bolts
- 4 leveling bolts

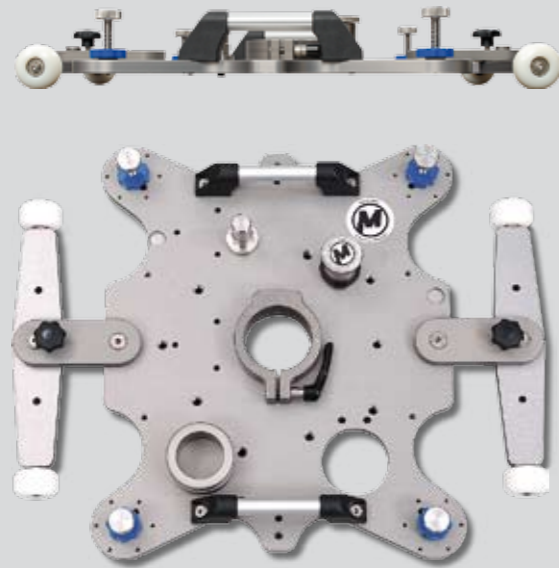

## Add-on options

... the only thing it can't do is fly



The optionally available Mitchell 4-way leveler extends the range of possible uses for the Rocker Dolly.

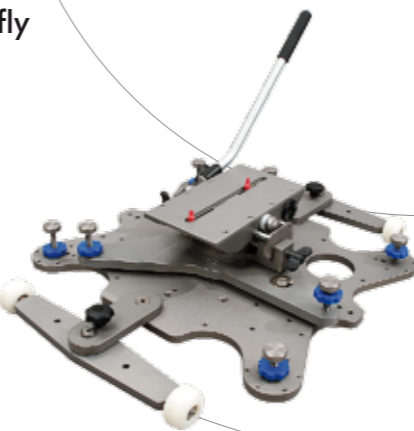

The MovieTech rocker plate can easily be placed on the resting positions provided on the dolly.



Another advantage of the Rocker Dolly is that it can be used as a leveling bazooka base. Even more applications are possible using MovieTech accessories: e.g. 40 cm risers with 150 mm ball adapter.



Fitted with a seat, a bazooka and a ball adapter, the Rocker Dolly can also be used as a ride-on unit (operator weight up to 100 kg).

The rocker plate for filming extremely low-level shots. The angle of inclination can be infinitely adjusted between  $-40^\circ$  and  $+45^\circ$  – the horizontal pan radius is 360 degrees. The adjusting screws and integrated spirit level allow the rocker plate to be set absolutely level.

As an option, the telescopic push rod makes it possible to easily push or pull the dolly. The angle and length can be quickly adjusted. The platform offers sufficient room for a wide range of accessories, from a remote head to a sandbag.

## Rocker Dolly used on rails/wheels

... on table wheels (standard)  
The basic set with studio wheels offers stable and smooth running characteristics on flat and level floors.



... on tubular tracks  
Using the optionally available rail wheel set, the Rocker Dolly can be used as a rail dolly on tubular tracks, for example.



... on Movie Tech Master Track or Movie Track

The Rocker Dolly also reveals its full potential on folding filming rails such as Movie Tech Master Track or Movie Track.

